

# Installation Guide

## **HempBLOCK LB 300**

LOAD BEARING HEMPCRETE BLOCK SYSTEM



**HEMPBLOCK  
USA**

[www.hempblockusa.com](http://www.hempblockusa.com)

There are four types of HempBLOCKS plus a concrete starter block

The average weight of a block is: 39.68 lbs

- 2 The HempBLOCK LB 300 Collection
- 3 HempBLOCK LB 300
- 4 Laying The First Blocks
- 4 Standard Walls
- 5 Posts
- 6 Windows Sills
- 6 Lintels
- 7 Concrete Floors
- 8 Bond Beams
- 9 Windows
- 10 Finishes
- 11 Site Specific Tools and Materials

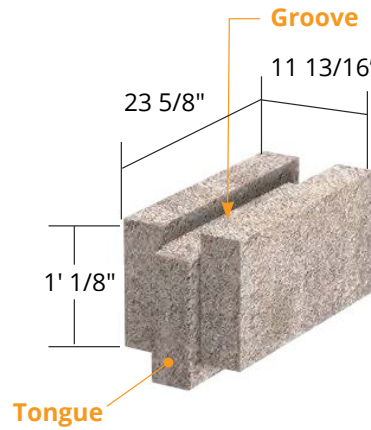

**HempBlock LB 300 S (standard)**

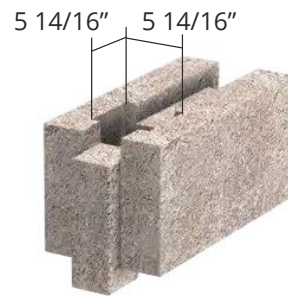

**HempBlock LB 300 C (column)**



**HempBlock LB 300 C2 (double column)**

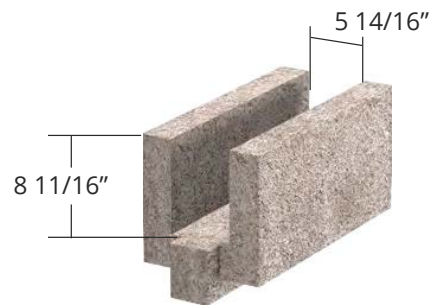

**HempBlock LB 300 U (U shape, Lintel & Bondbeam)**

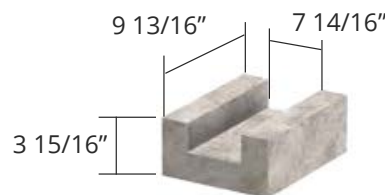

**Concrete Starting Block  
Weight: 7.2 lbs**

**NOTE** All measurements have been converted from millimeters to inches to the 16th of an inch to ensure a reason degree of accuracy.



## THE HEMP BLOCK PROCESS

The HempBLOCK building system consists of dry stack interlocking hempcrete blocks incorporating a reinforced concrete post and beam construction system.

HempBLOCK USA is the exclusive distributor of BIOSYS and MULTICHANVRE blocks, re-branded as HempBLOCK in America, Australia and New Zealand.

## WHY CHOOSE THE HEMP BLOCK?

### FOR COMFORT

- High acoustic comfort
- Good thermal capacity and inertia
- No VOC emissions
- Constant natural atmosphere
- Filters the air

### FOR PERFORMANCE

- Thermal resistance
- Humidity control
- Acoustic dampening
- CO2 storage
- Fire resistance
- 2 in 1: Structure and insulation

### FOR INNOVATION

- Monolithic plant-based matrix
- Unique patented format and interlocking system
- Interlocking assembly, no mortar

### FOR THE ENVIRONMENT

- Natural materials
- Hempcrete is 100% renewable
- Dries naturally, hardens to rock over time
- Carbon negative building system. Captures more carbon than used when building is finished.



### FOR SAVINGS

- Easily incorporated into existing building practices
- No additional insulation required
- Easy to handle
- Simple interlocking assembly
- Fast construction of walls with minimal waste and material handling
- Approximately 5.4 blocks per 10 sq ft, 53 sq ft per hour or about 270 sq ft of wall per day.

## HEMP BLOCKS ARE MADE OF ONLY NATURAL INGREDIENTS:

### HEMP WOOD

The wooden inner particles of the industrial hemp stem. Its innate structure gives it a high thermal hygroscopic and acoustic performance.



### NATURAL CEMENT

Formula that will last the duration of time. Excellent durability. Permeable to water vapor (Hygroscopic). Captures CO2.



### WATER



# Laying the First Blocks

- 1 Set back of the slab edge is 1 15/16"
- 2 Starter bars that will connect with the steel reinforcing of the columns.  
**NOTE** Center of starter bars is 3 15/16" off the edge of the slab.

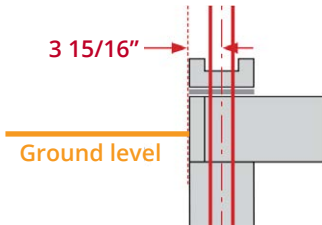

Center of starter bars

- 3a Water repellent mortar on dampcourse / termite proofing to the embed starter blocks.
- 3b Height of the water-repellent mortar bed to be defined according to the level of the finished interior floor.
- 4 Installation of a dampcourse on the starter blocks.

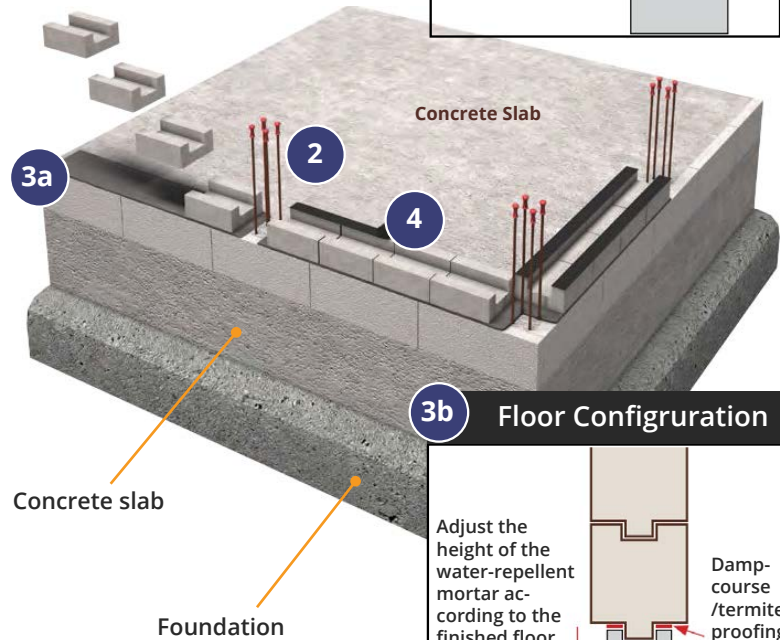

## 1 Floor Configuration

Dimension of the finished building

1 15/16" →  
Ground level

Foundation

## 3b Floor Configuration

Adjust the height of the water-repellent mortar according to the finished floor.

Damp-course / termite proofing

Slab

# Standard Walls

- 1 Install the blocks by simply interlocking them in a staggered fashion with an overlap of at least 3 15/16"
- 2 To fill voids greater than 3 15/16" cut blocks and use a saw to fill the gaps bigger than 3 15/16" cut the blocks and create a groove with a saw.
- 3 When there is a gap of less than 3 15/16" between two blocks, mix some hempcrete with Prompt Natural Cement and apply it in the cavity (with a trowel and a float).
- 4 Cut a section out of the blocks that form the corners to ensure continuity of the groove.

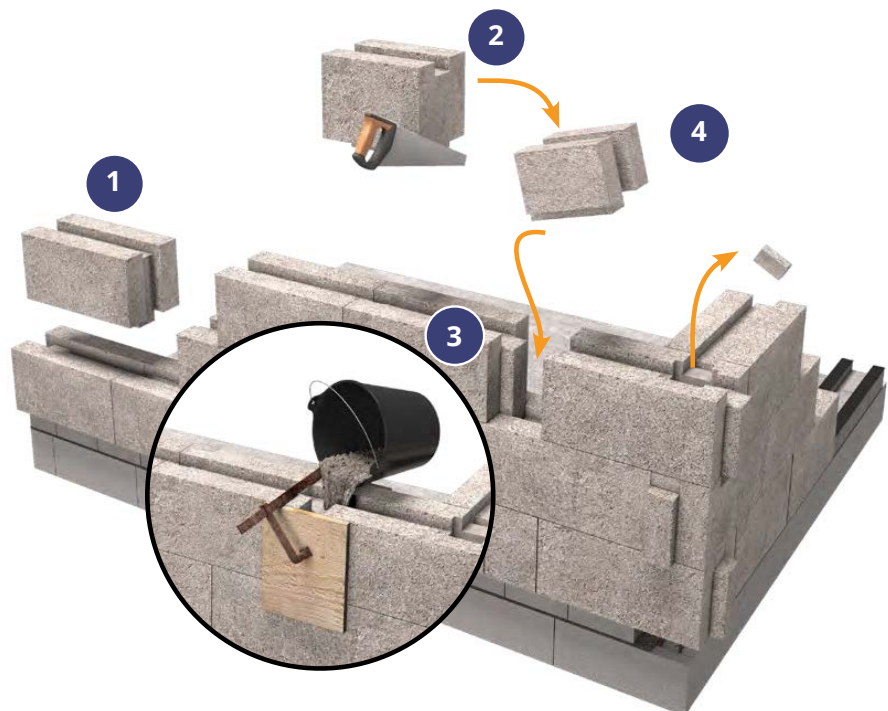

# Posts

- 1a Cut the tongues in order to lay them across on the corners.
- 1b Close the remaining openings with the off-cuts from step 1a (green section).
- 2 Cutting a post block to create a half post block. Assemble the posts alternating between post blocks and half-post blocks in the (in this case the right side) of the opening.
- 3 At the height of the window lintels (7 rows of standard blocks), use clamps and bars as shown below. These clamps are installed at each post except for the corners to assure it is plumb before pouring the concrete.
- 4 Install formwork at the bottom of the post.
- 5 Installation of steel cage (dimensions according to engineering specifications) in the void created by the column or double column blocks. The steel reinforcing must be centered using plastic spacers to ensure it is surrounded by a minimum of 1" of concrete.
- 6 Brace the wall to maintain plumb with a strut against the block keeper bars before pouring the columns.
- 7 Fill the columns with concrete in accordance with the engineer's requirements. Pouring the concrete in stages of maximum 7' 1/16" of height. Do not use vibration. Use a concrete pump very slow and with extreme care for the blocks not to crack, overload or leak.
- 8 Cut the tongues.

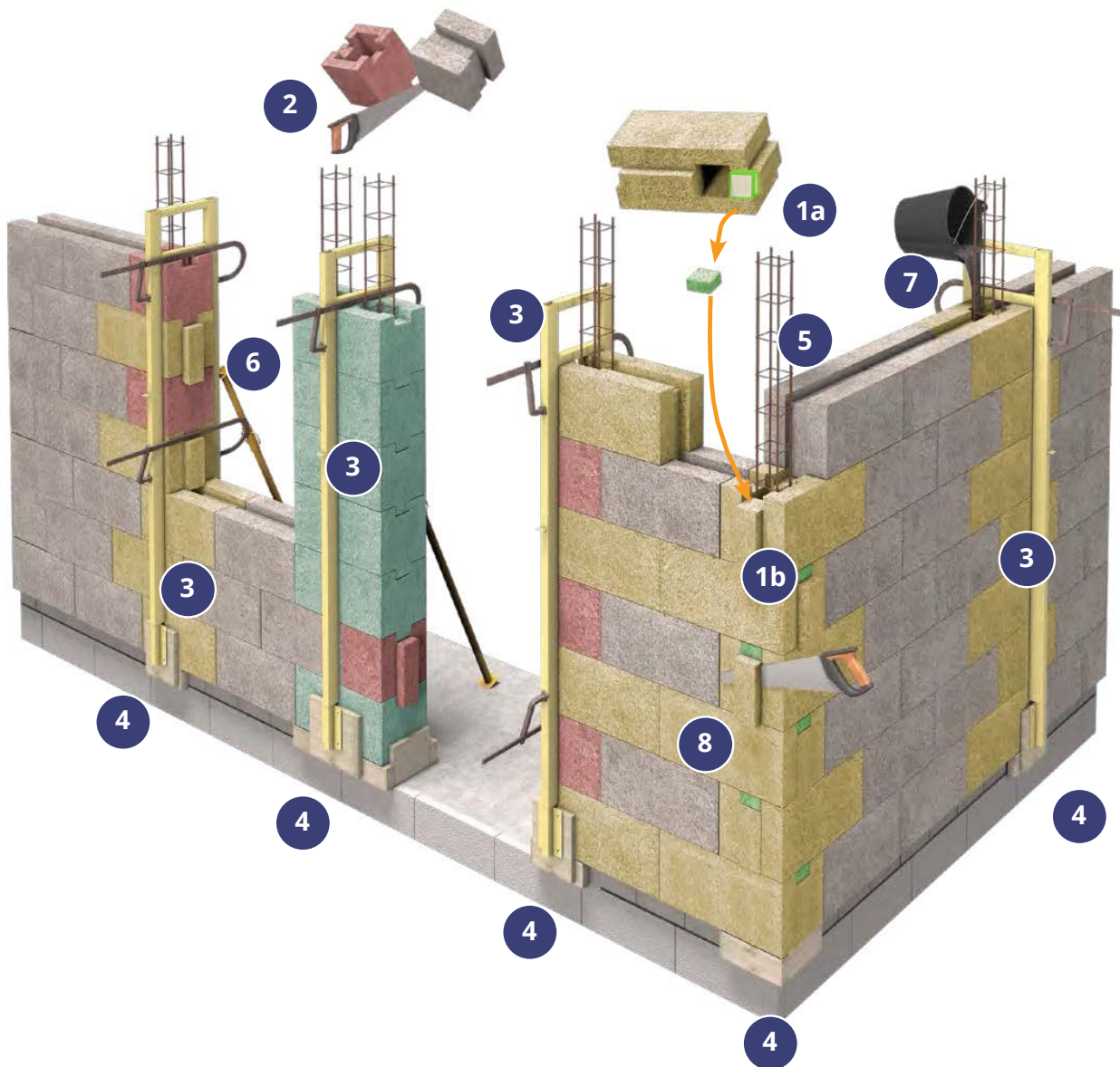



# Window Sills

- 1 Cut the tongue so that the steel of the window sill is connected with the steel of the uprightposts.
- 2 Connect the sill steel in the groove with the posts prior to pouring the sill.
- 3 Pour the sill concrete after the posts have been poured. Keep steel clear from the block surfaces.

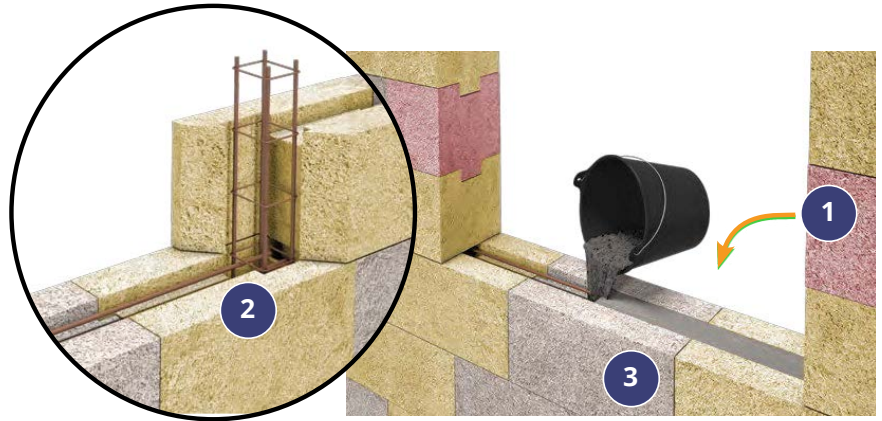

# Lintels

## LINTEL OF A ROLLER SHUTTER CASING

- 1 Pre-cut the post blocks.
- 2 Install the half shutter casing.
- 3 Cut the tongue under the blocks.
- 4 Place the blocks on a bed of mortar.

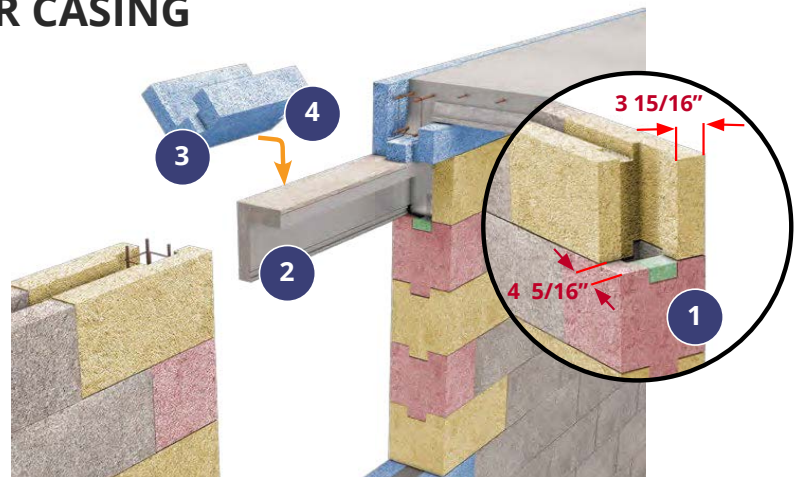

## LINTEL BLOCK CONSTRUCTION

- 1 Place the supports of the lintel U Blocks.
- 2 Cut the tongues of the lintel U blocks.
- 3 Place the Lintel blocks with 2 15/16\" data-bbox="57 663 398 811"/>

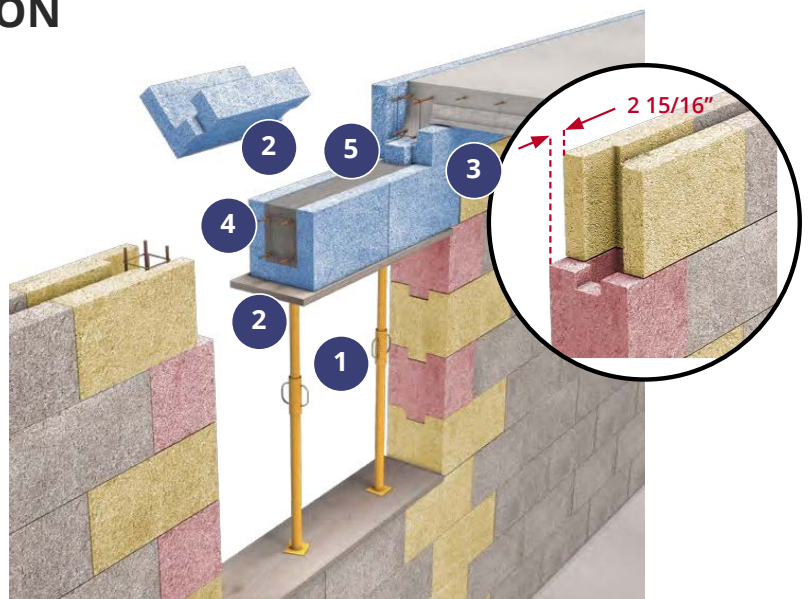

## Continuation of a wall on a second floor - 2 options

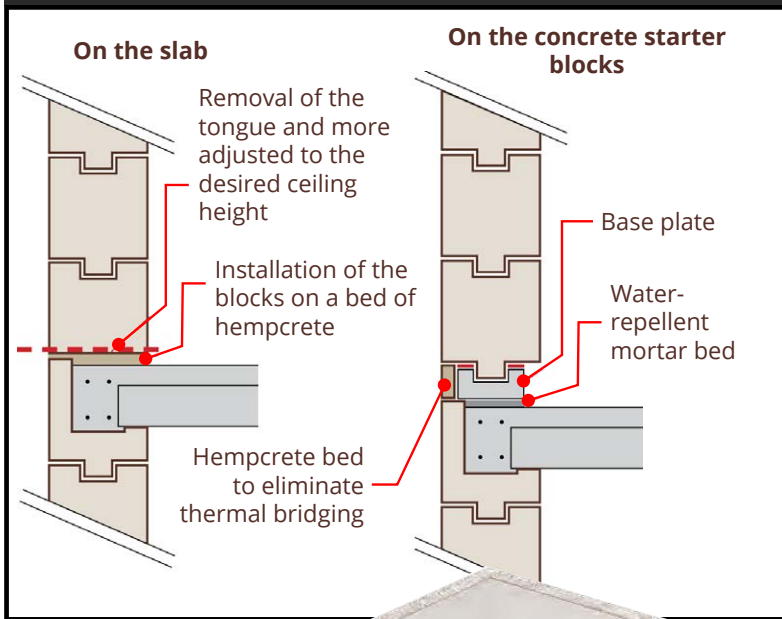

- 1 Cut the U blocks to ensure continuity of the bond beam.
  - 2 Installation of the steel reinforcing to engineer's specifications
  - 3 Strutting of the edges.
  - 4 Installation the beams / floor.
  - 5 Installation of the floor segments and reinforcing.
  - 6 Pour the slab and bond beam in one go.
- Installation of the flooring according to engineer's specifications

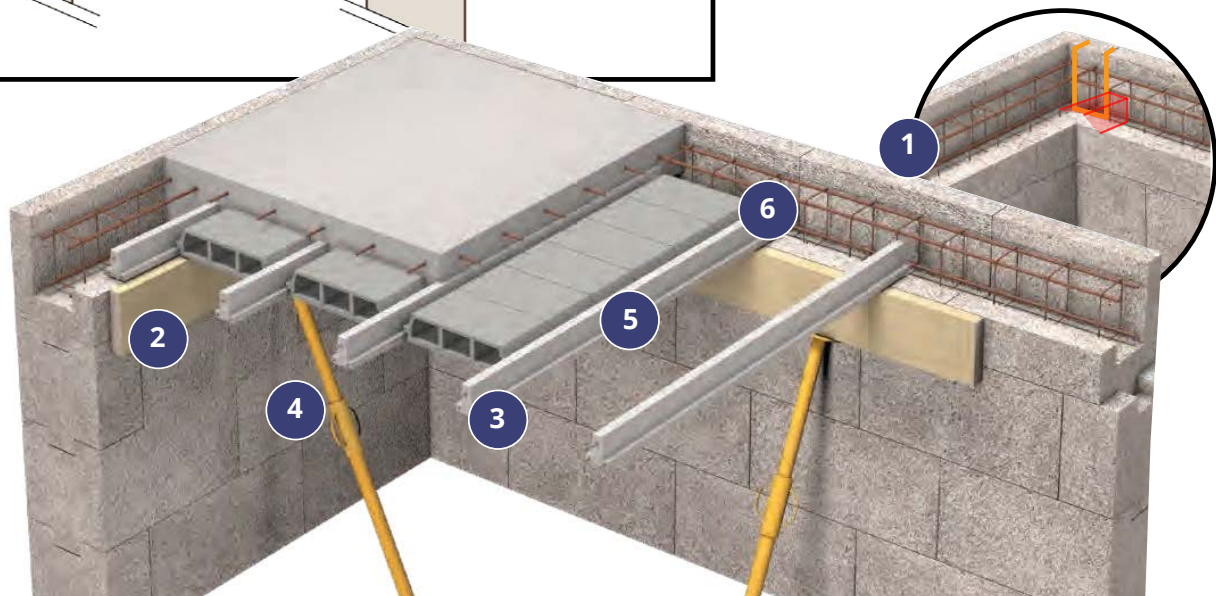

## Heights between the top of the floor slab and the bottom of the ceiling

### U Block cut off heights

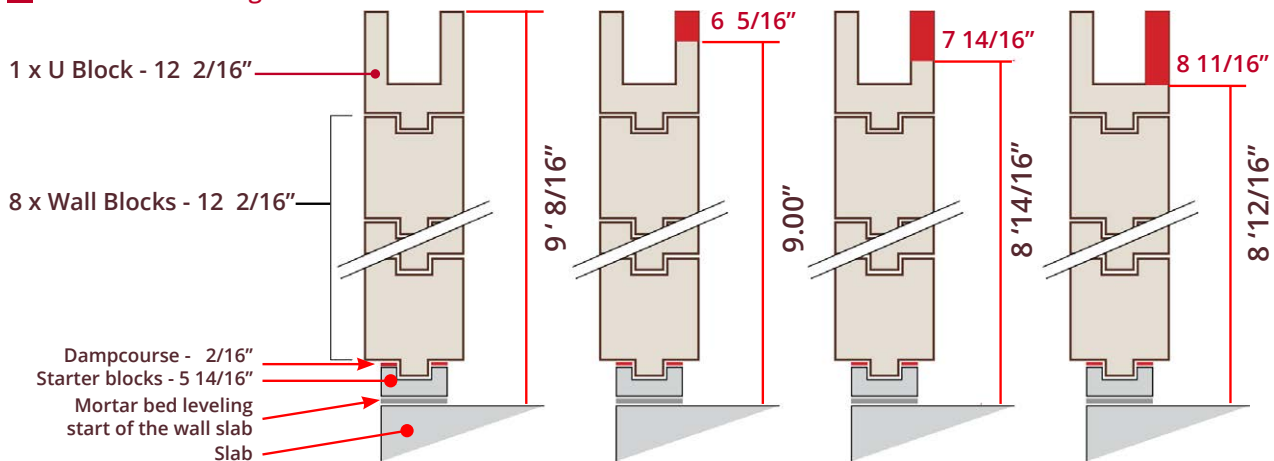

# Bond Beams

- 1 Set out gable slope by retracting 12 2/16" of the roof pitch line.
- 2 Cut the blocks with the appropriate tools and guiding system.
- 3 Create a groove.
- 4 Cut holes in the bond beam blocks at appropriate location in continuation with the posts.
- 5 Place and secure the bond beam reinforcing to engineers specifications.
- 6 Pour concrete bondbeam to engineers specifications.
- 7 The maximum height for a bond beam in a wall is on top of the 8 th layer of blocks. The top of this bond beam will be approximately 9'8/16" of ffl. This is to create a bond beam along the entire perimeter of the walls. Consult your engineer to comply with local building codes.

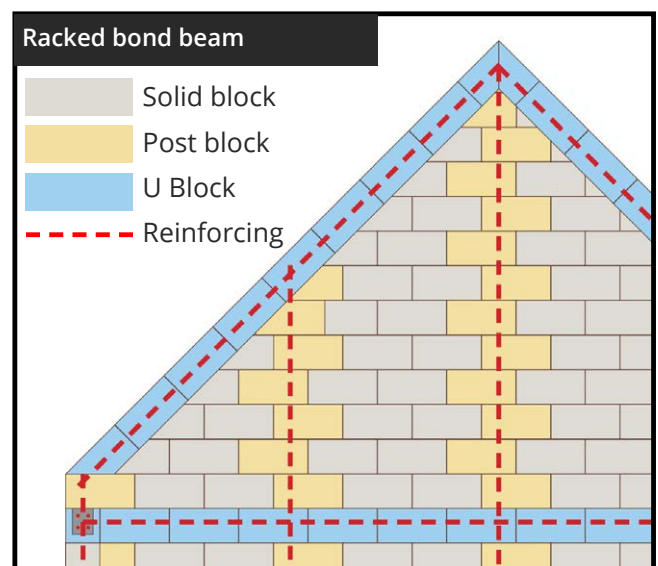
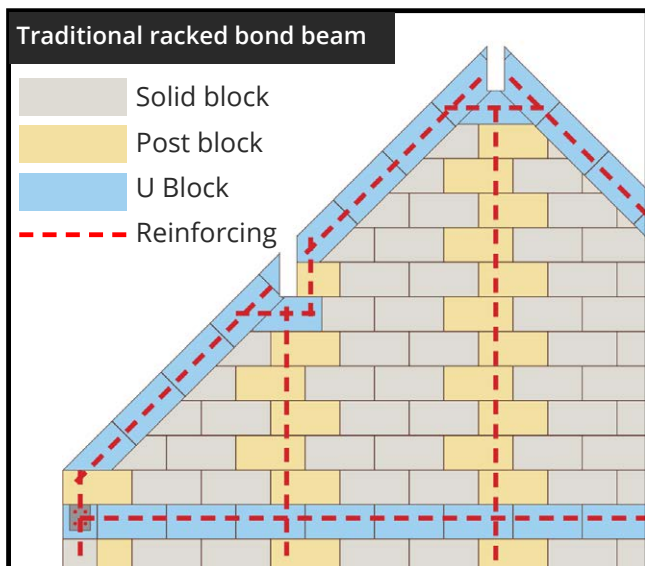
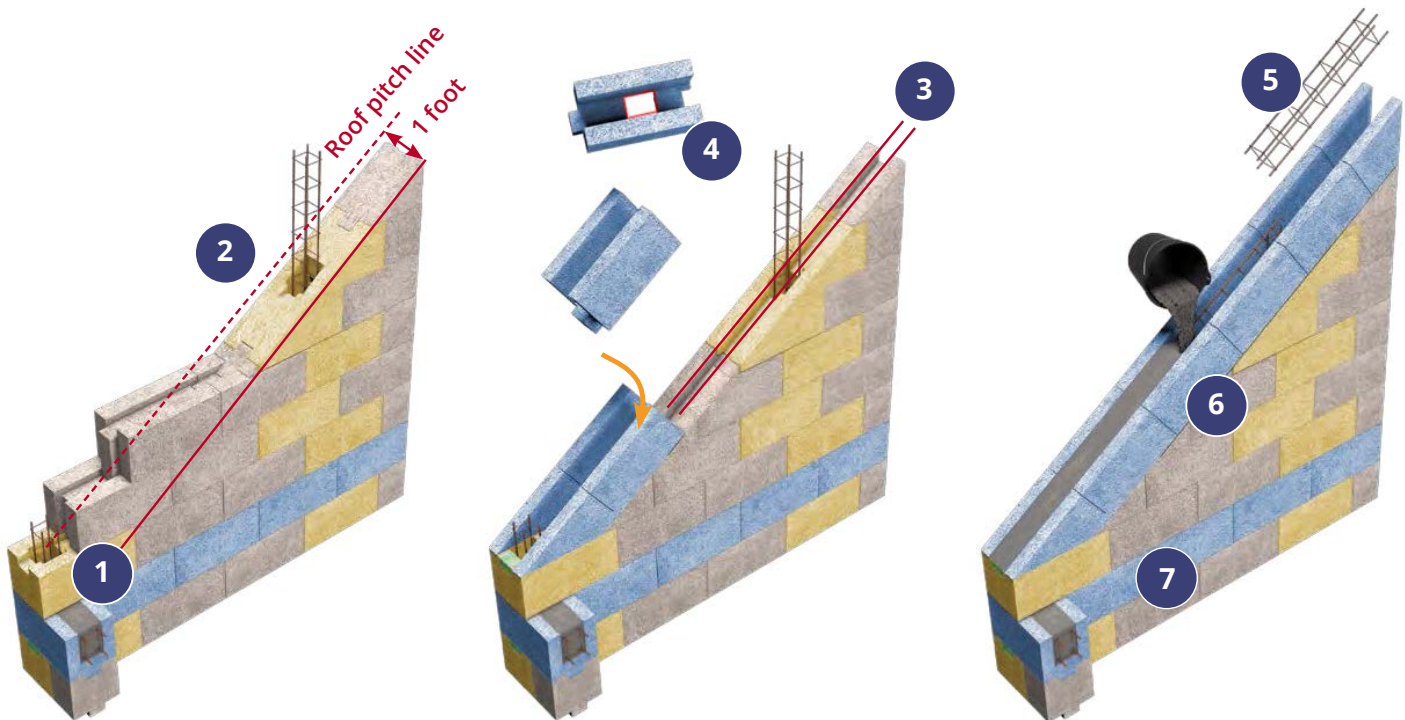



## Installation of roller shutter system

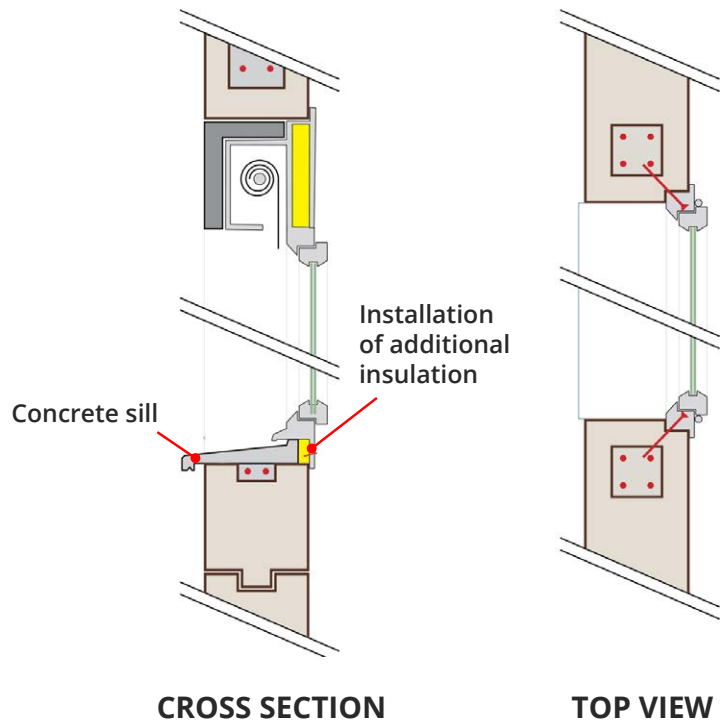

## Installation of hinged shutters

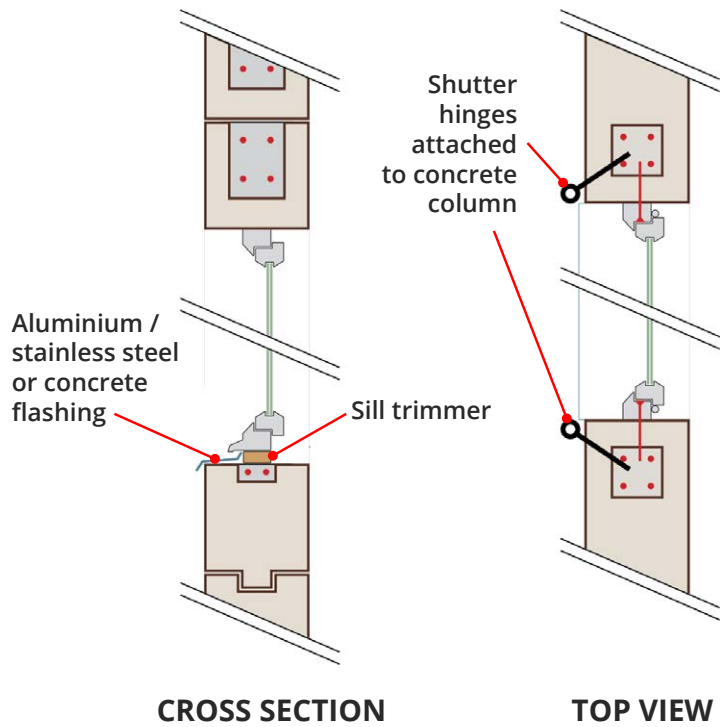

## EXTERIOR RENDER FINISH

Choose only HBU approved lime render finishes.

The whole outer surface should be meshed and angled and coated twice as per render standards. A key, scratch or stipple coat is not needed. The blocks provide excellent adhesion of the render.

Render to manufacturers specifications. Contact our technical team for further advice if required.

Lime render finishes assure breathability of the hempcrete walls. HBU provides quality render in a variety of colours.



## INTERIOR FINISHING

Many interior finishes are compatible with the HBU BLOCKS. Among them, lime render, claybased, earth-based renders and plaster board.

### Embedding services

Services such as phone, power and water need to be ducted and mounted in trenches. Create the grooves in the surface with the appropriate tools and the use of a hole saw and chisel or drill holes that match up with the hole of the underlying block.

After services have been installed the trench will be filled with a filler that is compatible with the interior render.



## SPECIFIC TOOLS

### BIOSYS ELECTRIC WALL CHASER

This tool creates a groove in the block after it has been cut. The groove created allows it to interlock with the tongue of the following blocks.



### RETAINING PINS \*

Maintains the plumb of the column blocks before and during the casting and setting of the concrete fill. Secures the wall against high winds before columns have been poured. Unique design for easy installation. Plates at the bottom create a temporary form-work of the lower part of the block.

*\* These tools are easily made by a steel worker  
Please ask our technicians for construction details.*



### CUTTING BLOCKS

HempBLOCKS are easily cut with an alligator saw, handsaw, chainsaw or reciprocating saw.

*TIP: It may be worth using a band saw for large jobs.*



## RECOMMENDED PRODUCTS AVAILABLE

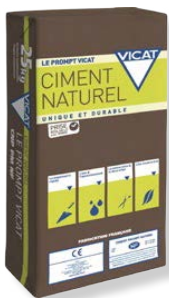

### VICAT PROMPT NATURAL CEMENT

Vicat Prompt Natural Cement. This cement binder is available in 55.11 lb bags. Mixed with construction grade hemp-wood it will create hempcrete to fill voids etc.



### BAG OF HEMP WOOD (SHIVE)

This 52.83 gallon bale of hemp-wood (or shive) is for the onsite mixing of hempcrete required for patch works. Use the Vicat Prompt Natural Cement to create the hempcrete.



### TEMPO RETARDER

Specially designed to regulate the start of setting of the Prompt Natural Cement, TEMPO regulates the timing of the professional installer.

This retarder is specifically made for hempcrete.



### LIME RENDER

For exterior and interior finishing of the hempcrete block walls. Order the lime finish together with your hemp blocks, conveniently arriving at your building site at the same time.



## THE HempBLOCK

HempBLOCK USA is the sole American distributor of the BIOSYS system. The factory (shown above) has been built to exclusively manufacture Hempcrete Blocks. The factory guarantees a controlled manufacturing process and a very high quality production of hempcrete blocks. The premises also has an undercover space to allow the blocks to dry naturally.

## TECHNICAL SUPPORT

The installation and manufacturers guidelines provided in this document must be used when designing and constructing walls using our HempBLOCKs and the associated load bearing system. While the information provides technical guidance it does not, in any way, replace the need for your design to be certified by a suitability qualified and experienced engineer to ensure it complies with your local building codes and receives the necessary approvals from the relevant authorities prior to commencing any work. Consult us for technical guidance on your construction project.

## OUR PARTNERS

**+Biosys**



**VIEILLE**  
matériaux 



**HEMPBLOCK  
USA**

**Efficient Building Technology**

**CONTACT** Johan Tijssen *Director* | [johan@hempblockusa.com](mailto:johan@hempblockusa.com)

Toll-free (855) 795-0012

[www.hempblockusa.com](http://www.hempblockusa.com)